

Product Description

The rotary vacuum paddle dryer is a drying system used to obtain dry powder from wet cake or solutions. The drying operation is generally a batch process and often carried out under vacuum. The product is heated through direct contact with the heated vessel and agitator surfaces. The heating of the dryer can be accomplished by use of steam or adequate heat transfer fluid.

Paddle Dryer Applications

In addition to standard batch drying applications, the paddle dryer can also be used for:

- Low temperature drying
- Reaction
- Crystallization
- Extraction of useful liquids
- Recovery of solvents

Paddle Dryer Features

The paddle dryer is adequately designed to counter stresses developed by vacuum and temperature cycles in the various heated parts. The standard design of the paddle dryer system includes a dust filter, condenser, receiver and vacuum pump. Other features include:



Hollow shaft and paddles

The hollow rotating agitator shaft imparts heat to the product, scrapes the shell wall, tumbles the product for maximum heat transfer and discharges product when required.



Discharge Valve

User friendly design provides vacuum tight closing when the material is processed and quick opening facilitates filling of bags when material is discharged and packed.

A pharmaceutical design is also available for GMP compliance with additional features, including:

- Full door opening for ease of operation, cleaning, inspection, and validation.
- Mechanical Seal to avoid product contamination.
- Clean area installation with stainless steel partition wall between the process area and the drives.
- Machined and mirror polished inside surfaces with PTFE Scrapers.
- Sterile Operation



15,000 L Rotary Vacuum Paddle Dryer with simple support.



1500 L Rotary Vacuum Paddle Dryer Pharma Series with GMP design.

PADDLE DRYER ADVANTAGES

- Versatile in process applications
- High energy efficiency
- Low operating costs compared to other types of dryers.
- Large heat transfer area available on paddles and shaft give maximum heat transfer rates..
- The scrapers have minimum calculated clearance from the shell to keep the shell clean and increase the heat transfer co-efficient.

SPECIFICATIONS

- Stainless steel or Hastelloy construction
- Designed as per ASME Pressure Vessel Code
- 25 to 60,000 liters capacity
- Up to 200 Hp designs

Standard Design

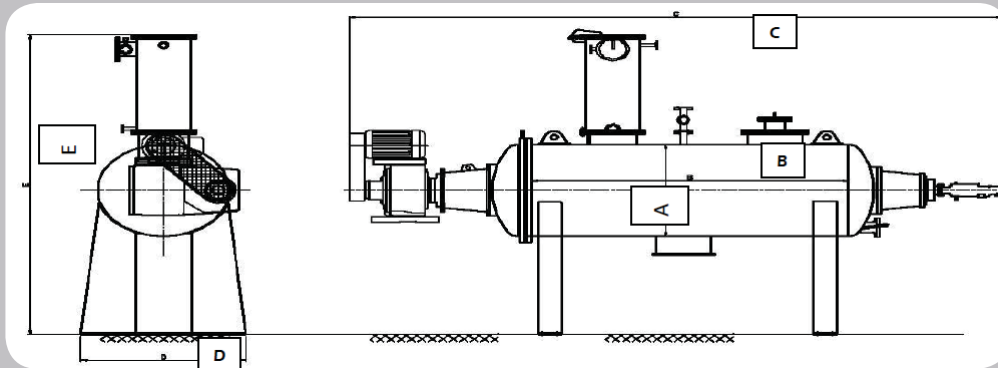

Model	Net Volume (Litres)	Usable Volume (Litres)	Inner Diameter (mm)	Shell Length (mm)	Total Length (mm)	Base Width (mm)	Overall Height (mm)	Drive HP (Low)	Drive HP (High)	Max RPM	Dust Filter (Area) (m ²)	HTA (m ²)	Discharge Valve (mm)
			A	B	C	D	E						
HLD-00400	400	280	600	1450	3270	900	2100	5	10	15	0.50	3.50	100
HLD-00500	500	350	625	1665	3800	950	2200	10	15	15	0.50	4.00	100
HLD-01000	1000	700	800	2030	4600	1200	2800	15	25	12	0.80	6.00	150
HLD-01500	1500	1050	915	2280	5200	1400	3200	20	25	10	0.90	7.50	150
HLD-02000	2000	1400	1000	2650	6000	1500	3500	25	30	8	1.20	9.50	200
HLD-02500	2500	1750	1100	2740	6200	1650	3850	30	40	8	1.50	11.00	200
HLD-03000	3000	2100	1200	2750	6200	1800	4200	30	40	8	1.50	11.50	200
HLD-04000	4000	2800	1350	2920	6600	2050	4750	30	50	8	2.00	15.50	200
HLD-05000	5000	3500	1450	3225	7250	2200	5100	40	50	8	2.40	18.00	200
HLD-06000	6000	4200	1450	3880	8750	2200	5100	40	60	8	2.80	20.50	200
HLD-07500	7500	5250	1550	4260	9600	2350	5500	50	60	8	3.10	23.50	250
HLD-10000	10000	7000	1850	4040	9100	2800	6500	60	75	7	3.90	30.00	250
HLD-12500	12500	8750	1950	4550	10250	2950	6850	60	100	7	4.10	33.00	300
HLD-15000	15000	10500	2100	4595	11500	3150	7400	75	100	7	4.75	37.00	300
HLD-20000	20000	14000	2300	5160	11600	3450	8100	100	120	7	6.00	47.00	350
HLD-25000	25000	17500	2500	5462	12290	3750	8750	120	150	6	6.50	51.00	350
HLD-30000	30000	21000	2500	6885	15500	3750	8750	150	180	5	7.50	56.00	400

Pharmaceutical Design

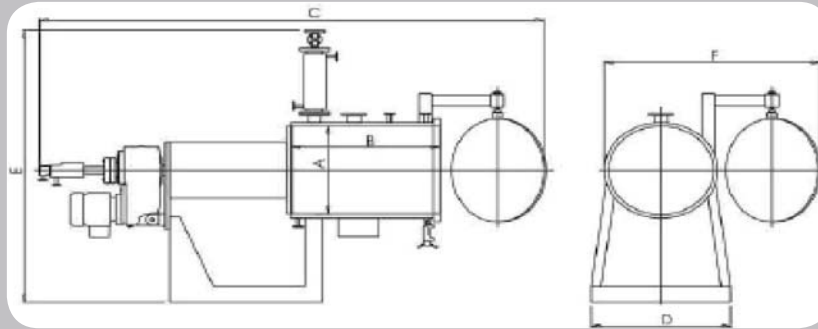

Model – Pharma Series	Net Volume (Litres)	Usable Volume (Litres)	Inner Diameter (mm)		Total Length (mm)	Base Width (mm)	Overall Height (mm)	Open Door Width (mm)	Drive HP (Low)	Drive HP (High)	Max RPM	Dust Filter Area (m ²)	HTA (m ²)	Discharge Valve (mm)
			A	B										
HLDP-0050	50	35	400	550	2200	600	1600	1200	2	5	15	0.10	0.75	50
HLDP-0100	100	70	500	675	2700	750	2000	1500	3	5	15	0.20	1.20	75
HLDP-0150	150	105	550	950	3800	825	2200	1650	3	7.5	15	0.25	1.60	100
HLDP-0300	300	210	650	1175	4700	975	2600	1950	5	10	13	0.35	2.50	100
HLDP-0500	500	350	800	1325	5300	1200	3200	2400	5	15	13	0.50	3.50	100
HLDP-0750	750	525	1000	1225	4900	1500	4000	3000	7.5	20	10	0.60	4.00	150
HLDP-1000	1000	700	1000	1650	6600	1500	4000	3000	7.5	25	9	0.70	5.50	150
HLDP-1500	1500	1050	1200	1650	6600	1800	4800	3600	10	25	9	0.90	6.50	150
HLDP-2000	2000	1400	1350	1660	6640	2025	5400	4050	15	30	8	1.20	7.50	200
HLDP-2500	2500	1750	1450	1750	7000	2175	5800	4350	20	40	8	1.40	9.40	200
HLDP-3000	3000	2100	1550	1810	7240	2325	6200	4650	25	40	7	1.50	9.60	200
HLDP-4000	4000	2800	1700	2045	8180	2550	6800	5100	30	50	7	1.65	12.00	200
HLDP-5000	5000	3500	1850	2180	8720	2775	7400	5550	40	50	7	1.90	15.00	200

Options

- Non-heated shaft and flat ends
- Conventional Jacket or half pipe coil heated
- Steam, Water or thermal Oil heated
- Shaft mounted or skid mounted gearbox
- Stuffing Box or Mechanical Seal
- Optional lump breakers or choppers
- CIP
- Pneumatic Discharge Valve
- Scraper clearance of 1mm or less

De Dietrich Process Systems, Inc.

244 Sheffield Street
Mountainside, NJ 07092

P 908.317.2585
F 908.889.4960

www.ddpsinc.com
sales@ddpsinc.com

