



# POWDER HANDLING CASE STUDY

**Customer**

Global Chemical Manufacturer  
(Herbicides Division)

**Location**

Texas, USA

**Process Summary**

Blending of powders  
(off-specification powders with  
approved material)

**Customer's Problem**

Off-specification powders were  
previously being discarded

**Powders**

Miscellaneous herbicides

**DDPS Actions**

Testing completed in DDPS Charlotte test facility to demonstrate  
conveyance of powders across extended transfer distance (120 feet)

**Final Solution**

Big Bag station and Powder Pump 8 with PLC/HMI; BB station provided  
with capability to allow charging to drums.

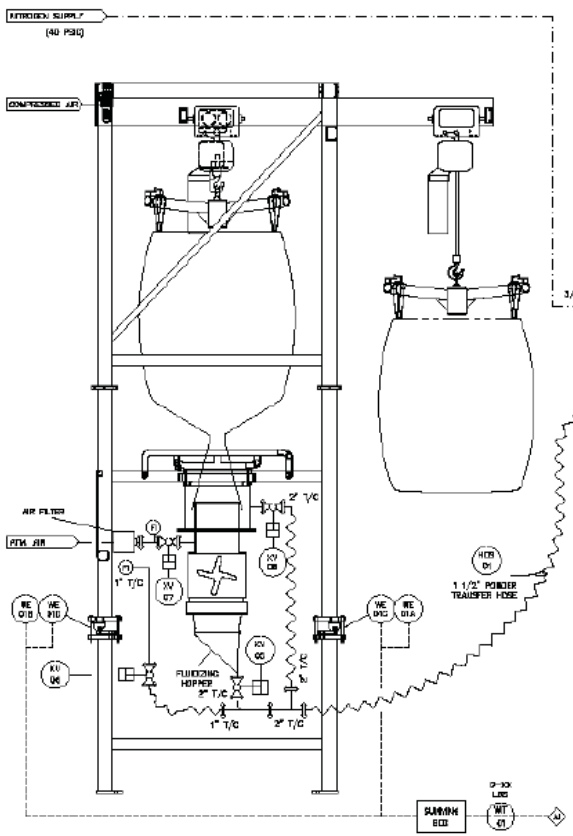

De Dietrich Process Systems, Inc.

244 Sheffield Street  
Mountainside, NJ 07092

P 908.317.2585  
F 908.889.4960

www.ddpsinc.com  
sales@ddpsinc.com



Case Study Number 030514  
rev 3/2014

Copyright © De Dietrich Process Systems, Inc. All rights reserved. The information contained in this brochure is believed to be reliable general guidelines for consideration of the products and services described herein. The information is general in nature and should not be considered applicable to any specific process or application. De Dietrich Process Systems, Inc. expressly disclaims any warranty, expressed or implied of fitness for any specific purpose in connection with the information contained herein.